

# Adjustable Flow Switches



## M-100 Series

Adjustable flow switch  
with right-angle flow

### Features

- Field adjustable
- Infinite flow range
- For corrosive and non-corrosive liquids or gases
- Extremely accurate and sensitive
- Low pressure drop
- All-Teflon® switch available
- Universal mounting available

### Applications

- Gas and liquid analyzers
- Atmosphere furnaces
- CVD tools
- Vacuum systems

The M-100 Series is an extremely sensitive flow switch. This has been engineering to monitor vital sample flow parameters for instrumentation in process control and inert blanket gases. It is used as an auxiliary alarm monitor for flow meters and is ideally suited for applications when installed on a by-pass for determination of filter plugging.

Infinite adjustment permits detection and signaling of very low fluid flows with the added capability of detection in high flows.

### Operation

The magnetic piston rests at the bottom of the switch with no flow present. Once flow is established, the piston moves upward responding to a by-pass flow and actuates the reed switch. The by-pass flow is controlled by a manual adjusting screw controlling the variable orifice. When flow decreases, the piston moves downward and the reed switch deactuates. Universal mounted units are outfitted with a spring which resets the piston.

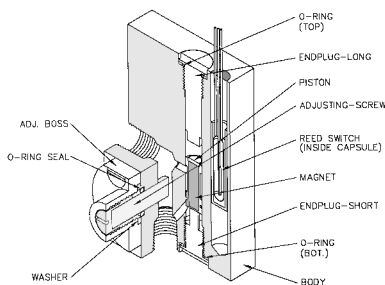

Illustrated is the M-100 Model with 1/8" ports.

### Custom Versions Available

Malema welcomes the opportunity to apply its flow sensor experience to work for its customers. Please contact the factory for any special requirements; such as ports, extreme temperature and pressure capabilities, etc.

### Calibration Range \*

Air: 50 - 60,000 scc/min  
Water: 3 - 950 cc/min

\* Maximum flows through switch are higher.  
For higher flow settings, contact factory.

### Specifications

Set Point Accuracy:  $\pm 10\%$  maximum  
Repeatability:  $\pm 1\%$   
Hysteresis: 15%

### Material Versions \*

- Brass
- 316 Stainless Steel
- Teflon®

\* Other materials available on request.

### Port Sizes

- 1/8" FNPT
- 1/4" FNPT

## Design Considerations/Construction

The M-100 Series comprises a Body, Piston, Endplugs, O-ring seals, and adjustment mechanism. Selecting a Flow Switch begins with selecting the body; this series is available in a number of materials. Adjustability is achieved by means of an adjustment screw controlling a bypass. Construction of the piston is important from a design perspective. We manufacture three (it is critical to select the correct piston for your application): 316 Stainless Steel, Teflon Encapsulated, and Special All-Metal piston.

(1) The standard piston is a 316 Stainless Steel piston with **epoxy** to hold the magnet in place. This piston is recommended for non-aggressive fluids and inert gases.

(2) The second piston that is available is a Teflon Encapsulated one. This piston is a magnet that has Teflon molded around it and then machined to the appropriate configuration. These pistons are primarily used in Teflon flow switches and also in other flow switch bodies (typically 316SS and Acrylic bodies) where customers prefer a piston that does not have epoxy in the fluid path; as well as a piston that is impervious to aggressive fluids and gases. This piston is highly recommended for medical applications. Hysteresis on these pistons does tend to be slightly higher (10 to 15%) than metal pistons due to frictional effects and surface adhesion considerations. Prior to selecting this piston, fluid temperatures and fluid compatibility with Teflon must be taken into account because certain aggressive chemicals at specific temperatures tend to swell Teflon causing the piston to change shape resulting in failure of the product.

(3) The third piston that is available is a Special All-Metal piston with **no epoxy** (only available in 316SS). This piston is fabricated in a proprietary process with only one weld seam (leak tested) which presents an all 316SS surface to the fluid path. This piston is recommended for those applications where the piston could experience a lot of cycling wear. This piston has been tested to 250,000 cycles at 125 psi.

## Standard Specifications by Materials

Housing	Brass	316SS	Teflon (PTFE)
Endplugs	Brass	316SS	Teflon (PFA Endplug)
Piston*	316SS	316SS	Teflon
Spring (only in Universal Mounting version)	Stainless Steel		N/A
Adjustment Screw (wetted area)	Teflon		
O-Rings	Buna N	Viton	Teflon Encapsulated and Teflon
<b>Pressure and Temperature Specifications</b>			
Maximum Operating (psig)	1,500	3,000	80
Burst (psig)	3,000	5,000	160
Maximum Operating Temperature	149 C (300°F)	149 C (300°F)	104 C (220°F)
<b>Reed Switch Data (Electrical Ratings)</b>	10 Watts SPST or 3 Watts SPDT (Hermetically Sealed) UL Recognized. File E47258.		
Reed Switch	Operating Temperature -40°C to 125°C		
Switching Voltage	200 VDC (170 VDC for SPDT)		
Breakdown Voltage	250 VDC (200 VDC for SPDT)		
DC Resistive	10 Watts (3 Watts for SPDT)		
AC Resistive	10 VA (3VA for SPDT)		
Switching Current	0.5 A (0.25 A for SPDT)		
Carrying Current	1.2 A (0.5A for SPDT)		
Lead Wires	No 24 to 18 AWG. 18" Length, Polymeric UL Recognized		
Lead Wires Color	SPST: 2 Blue wires; SPDT: Green - Common, Yellow - Normally Closed, Orange - Normally Open		
Flow Calibration	(Higher accuracy units available)		
Set Point Accuracy	10% maximum		
Set Point Differential (Deadband) **	15%		
Repeatability	± 1% maximum		

\* See "Design Considerations/Construction" above

\*\* With stainless steel piston

# Adjustable Flow Switches

## Reed Switch Ratings as Recognized by UL

SPST	120 V ac 24 V dc 50V dc	0.1 A general purpose 0.25 A resistive 0.25 A resistive
SPDT	120 V ac 10 V dc 24 V dc	0.1 A general purpose 0.25 A resistive 0.1 A resistive

## Certifications

- UL and Canadian UL Recognized for ordinary locations. File E138467
- Meet the intent of Directive 89/336/EEC for Electromagnetic Compatibility and Low Voltage Directive 73/23/EEC for Product Safety. Compliance was demonstrated to the following specifications as listed in the Official Journal of the European Communities: EMC Directive 89/336/EEC: EN 55011, Class B Radiated Emissions, EN 50082-1 (Immunity): IEC 801-2, Electrostatic Discharge Immunity, IEC 801-3, RF Electromagnetic Field Immunity; Low Voltage Directive 73/23/EEC: EN 61010-1, Safety Requirements for electrical equipment for measurement, control, and laboratory use.

## Installation & Maintenance

The standard switch has to be mounted vertically in the position shown on the previous page. Models suitable for universal mounting positions are available on request. Adequate filtration and sealing procedures should be used when mounting in flow lines. For detailed directions, please refer to our "Installation and Maintenance" sheet.

## Pressure Drop and Cv

$$\Delta P = \left[ \frac{Q}{Cv_f} \right]^2 ; \text{ where } Cv_f = Aq^2 + Bq + C$$

$\Delta P$  : the pressure drop in Inches of Water.

Q : the flow rate in scc/m of air.

q : the flow switch set point in scc/m of air.

A :  $1.54 \cdot 10^{-6}$

B : 0.336

C : 181

Cv at typical setpoints		
Water cc/m	Air cc/m	Cv
315	9,440	0.18
600	20,000	0.22
1,250	40,000	0.25

## Dimensional Drawings

Illustrated is the M-100 Model with 1/4" ports.

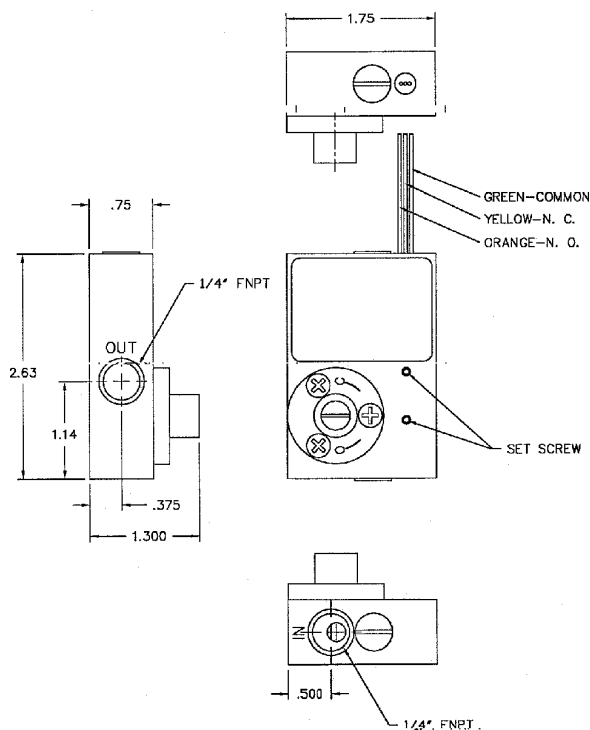

Illustrated is the M-100 Model with 1/8" ports.

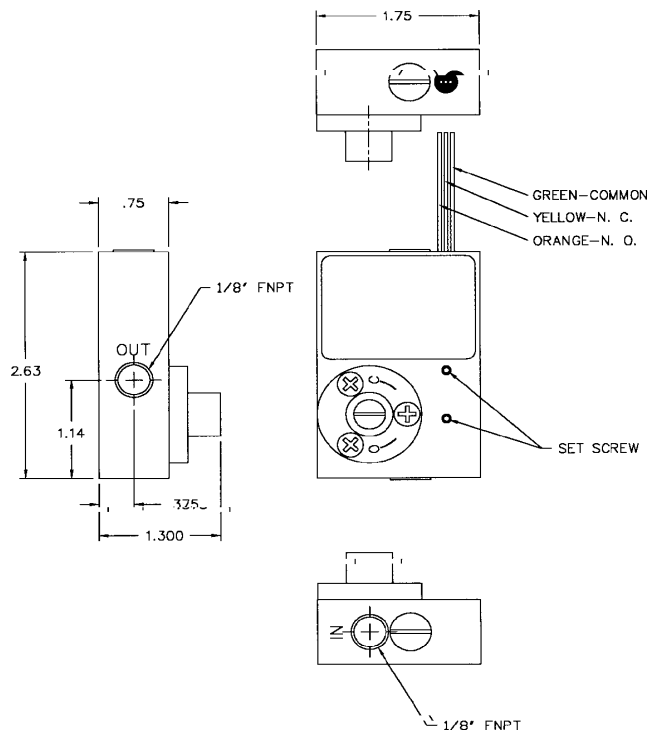

## Cut-Away Drawings

Illustrated is the M-100 Model with 1/4" ports.

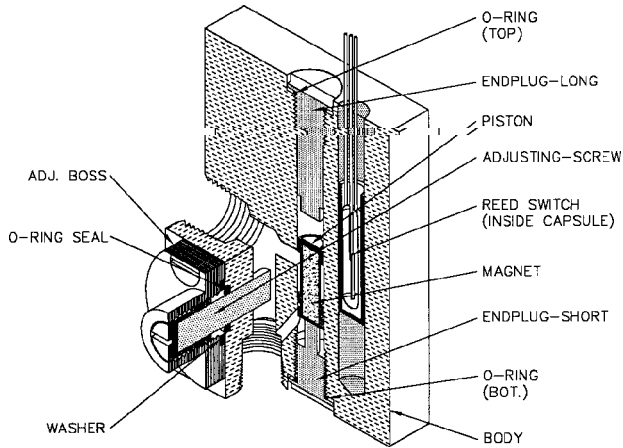

Illustrated is the M-100 Model with 1/8" ports and universal mounting.

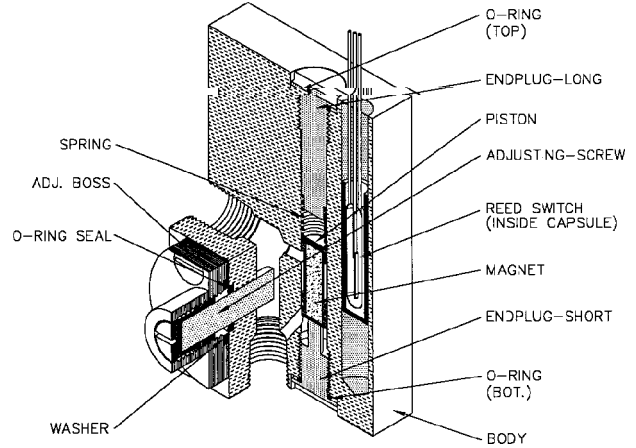

## Standard Flow Range Table

## Ordering Information

Standard Part Numbering							Options				
M	-	Model	-	Material	Port	Switch	Flow Range	-	Mounting	Piston	Seals
M	-	100	-	S	1	1	1	-	0	0	0
		100		B - Brass S - 316 Stainless T - Teflon®	1 - 1/8" 2 - 1/4"	1 - SPST N.O. 2 - SPST N.C. 3 - SPDT	1 - Low 2 - High		0 - Standard (Vertical) 1 - Universal Mounting (with spring)	0 - Standard* (316 SS with epoxy) 1 - Teflon® encapsulated 2 - All-316 SS (no epoxy)	0 - Standard** (Viton®) 1 - Kalrez® 3 - Teflon® 6 - Butyl 7 - Buna-N (Nitrile)

\* Standard Piston for Teflon® bodies is Teflon® encapsulated.

\*\* Standard Seals for Teflon® bodies is Teflon®.

Teflon®, Kalrez® and Viton® are registered trademarks of DuPont.