

# Adjustable Flow Switches



## M-200 Series

High flow,  
adjustable flow switch  
with right-angle flow

### Features

- Field adjustable – infinite flow range
- High repeatability
- Extremely sensitive
- Minimum pressure drop
- Position insensitive

### Applications

- Cleaning Tools in the semiconductor industry
- Cooling systems
- Water treatment systems
- Process flows

The M-200 Series flow switches are engineered and field tested for sensing increasing and decreasing flow rates of gases or liquids. Pressure variation effects are minimal. This series features such versatility, economy, and accuracy that they can be used in virtually any application requiring fool-proof inexpensive flow detection.

### Operation

The flow switch is activated by flow forcing a piston kept in place by a spring to travel past a reed switch. This provides a positive signal after a certain amount of travel. Set point adjustment is controlled by adjusting the positioning of the reed switch.

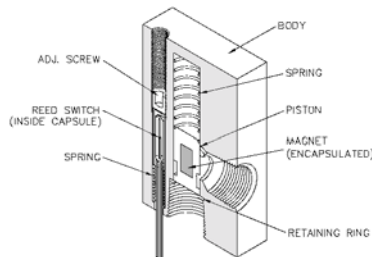

Illustrated is the M-200-B Model with 1/2" ports.

### Calibration Range \*

<b>3/8", 1/2", SAE8:</b>	Water: 0.03 - 5 gpm
	Air: 1 - 50 scfm
<b>3/4":</b>	Water: 0.2 - 10 gpm
	Air: 2 - 100 scfm

### Specifications

Set Point Accuracy:	±10% maximum
Repeatability:	±2%
Hysteresis:	30%

### Material Versions

- Acrylic
- 316 Stainless Steel
- Aluminium
- PTFE
- Brass

\* Other materials available on request.

### Port Sizes

- 3/8" FNPT
- 1/2" FNPT
- 3/4" FNPT
- SAE8

## Design Considerations/Construction

The M-200 Series comprises a Body, Piston, Spring, and a Retaining Ring. Selecting a Flow Switch begins with selecting the body; this series is available in a number of materials. The M-200 Series contains two moving parts (i.e. the piston and spring) and a retaining ring that are in the fluid path. Construction of the piston is important from a design perspective. We manufacture three types of pistons (it is critical to select the correct piston for your application): PTFE with epoxy, PTFE Encapsulated, and Special All-Metal piston.

(1) The standard piston is a PTFE piston with **epoxy** to hold the magnet in place. This piston is recommended for non-aggressive fluids and inert gases. Stainless Steel retaining rings are typically used with this piston type.

(2) The second piston that is available is a PTFE Encapsulated one. This piston is a magnet that has PTFE molded around it and then machined to the appropriate configuration. These pistons are primarily used in PTFE flow switches and also in other flow switch bodies (typically 316SS and Acrylic bodies) where customers prefer a piston that does not have epoxy in the fluid path; as well as a piston that is impervious to aggressive fluids and gases. This piston is highly recommended for medical applications. Hysteresis on these pistons does tend to be slightly higher (10 to 15%) than metal pistons due to frictional effects and surface adhesion considerations. Prior to selecting this piston, fluid temperatures and fluid compatibility with PTFE must be taken into account because certain aggressive chemicals at specific temperatures tend to swell PTFE causing the piston to change shape resulting in failure of the product. Stainless or PTFE-coated retaining rings can be used with this piston, along with a stainless spring (also coated).

(3) The third piston that is available is a Special All-Metal piston with **no epoxy** (only available in 316SS). This piston is fabricated in a proprietary process with only one weld seam (leak tested) which presents an all 316SS surface to the fluid path. This piston is recommended for those applications where the piston could experience a lot of cycling wear. This piston has been tested to 250,000 cycles at 125 psi. Stainless Steel retaining rings are recommended for this piston type.

## Standard Specifications by Materials

Housing	Acrylic	Brass	316SS	PTFE
Piston	PTFE	PTFE	PTFE	PTFE Encapsulated
Spring	Stainless Steel			PTFE Coated Stainless Steel
Retaining Ring*	Stainless Steel			PTFE Coated Stainless Steel or PTFE Ring
<b>Pressure and Temperature Specifications</b>				
Maximum Operating (psig)	200	1500	3000	200
Burst (psig)	400	3000	5000	600
Maximum Operating Temperature	77 c (170° F)	149 c (300° F)	149 c (300° F)	149 C (300° F)
<b>Reed Switch Data (Electrical Ratings)</b>	Reed Switch 10 Watts SPST or 3 Watts SPDT (Hermetically Sealed) UL Recognized. File E47258 Switching Voltage Breakdown Voltage DC Resistive AC Resistive Switching Current Carrying Current 200 VDC (170 VDC for SPDT) 250 VDC (200 VDC for SPDT) 10 Watts (3 Watts for SPDT) 10 VA (3VA for SPDT) 0.5 A (0.25 VA for SPDT) 1.2 A (0.5A for SPDT)			
Lead Wires	No. 24 to 18 AWG. 18" Length, Polymeric UL Recognized or Belden cable with connectors to suit			
Lead Wires Color	SPST: 2 Blue wires; SPDT: Green - Common, Yellow - Normally Closed, Orange - Normally Open			
Flow Calibration* Set Point Accuracy Set Point Differential Repeatability	(Higher accuracy units available) 10% maximum 30% (lower hysteresis on request) + 2% maximum			

\* See "Design Considerations/Construction" above

## Reed Switch Ratings as Recognized by UL

SPST	120 V ac 24 V dc 50 V dc	0.1 A general purpose 0.25 A resistive 0.25 A resistive
SPDT	120 V ac 10 V dc 24 V dc	0.1 A general purpose 0.25 A resistive 0.1 A resistive

# Adjustable Flow Switches

## Installation & Maintenance

This product can be mounted in any orientation. Adequate filtration and sealing procedures should be used when mounting in flow lines. For detailed directions, please refer to our "Installation and Maintenance" sheet.

## Certifications

- UL and Canadian UL Recognized for ordinary locations. File E138467
- Meet the intent of Directive 89/336/EEC for Electromagnetic Compatibility and Low Voltage Directive 73/23/EEC for Product Safety. Compliance was demonstrated to the following specifications as listed in the Official Journal of the European Communities: EMC Directive 89/336/EEC: EN 55011, Class B Radiated Emissions, EN 50082-1 (Immunity): IEC 801-2, Electrostatic Discharge Immunity, IEC 801-3, RF Electromagnetic Field Immunity; Low Voltage Directive 73/23/EEC: EN 61010-1, Safety Requirements for electrical equipment for measurement, control, and laboratory use.

## Cv

Cv values available upon request.

## Dimensional and Cut-Away Drawings

*Illustrated is the M-200 Model with 3/8" ports.*

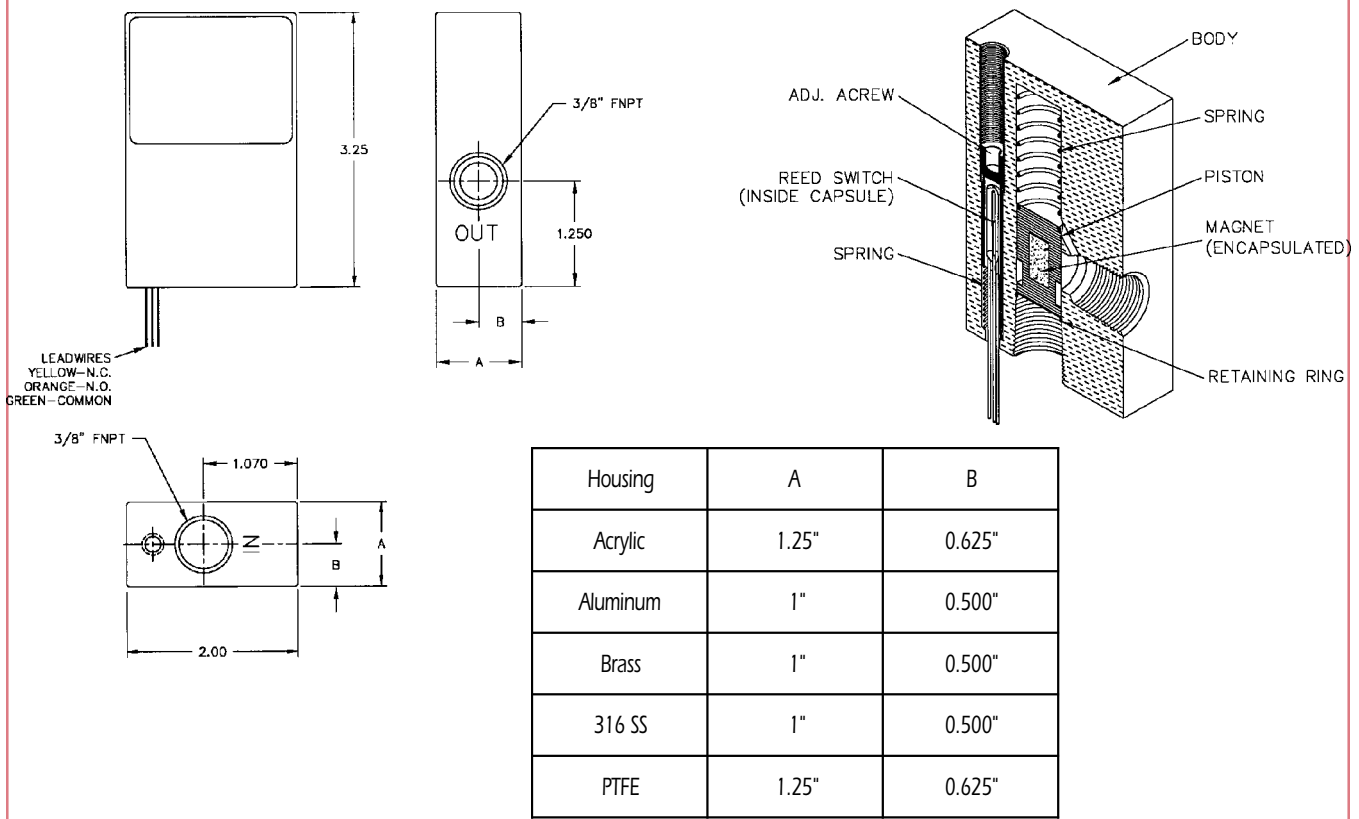

## Dimensional and Cut-Away Drawings (continued)

Illustrated below is the M-200 Model with 1/2" ports.

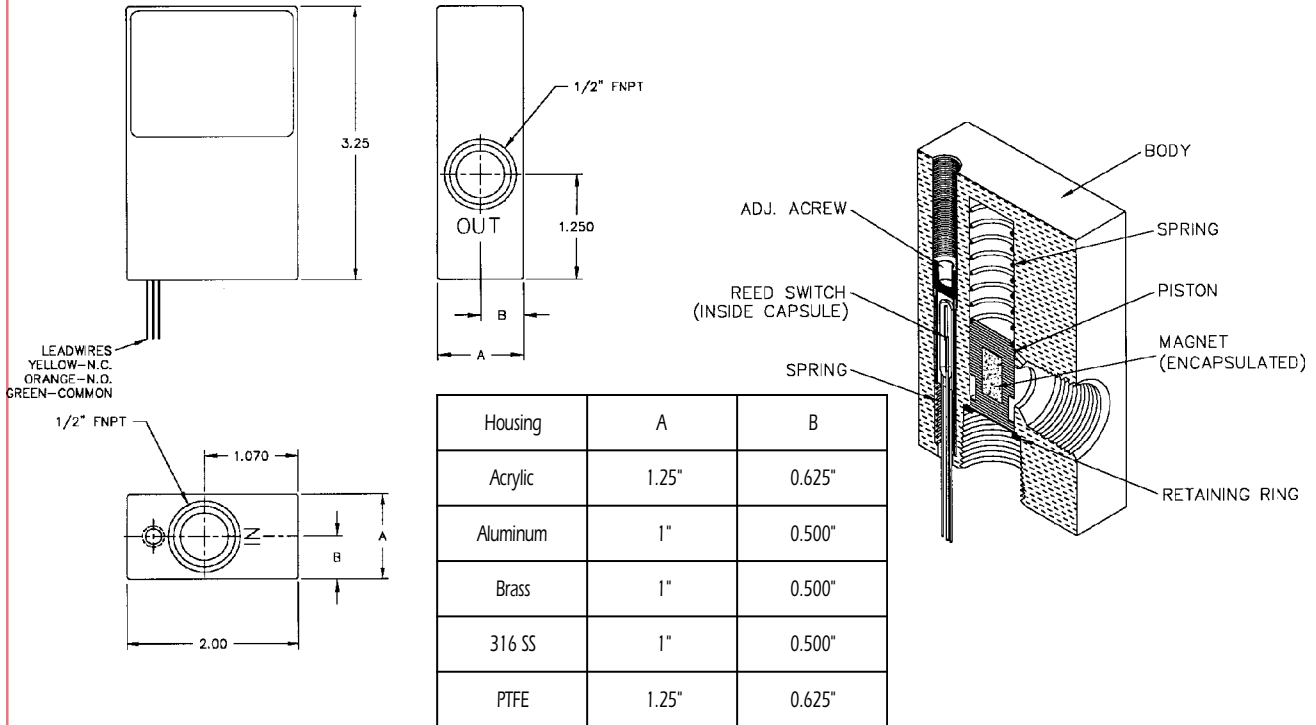

Illustrated below is the M-200 Model with 3/4" ports.

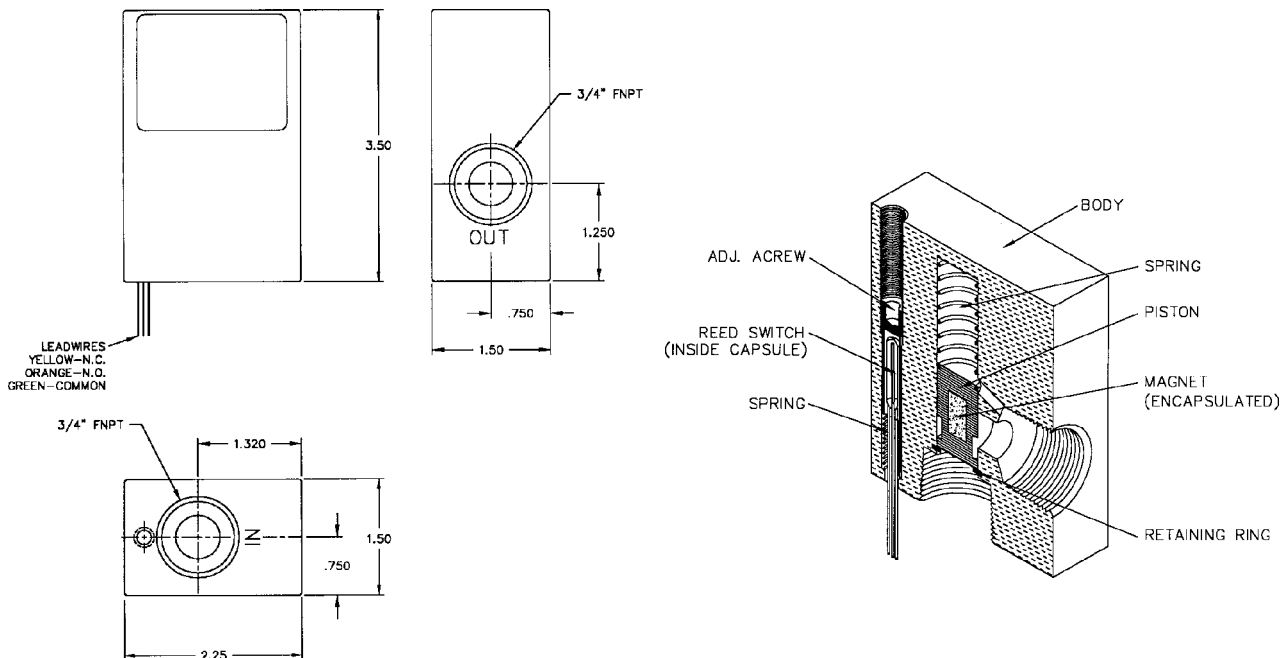

\* Note: The M-200 Model with 3/4" ports is only available in Brass, PTFE and 316 SS

# Adjustable Flow Switches

## Dimensional and Cut-Away Drawings (continued)

Illustrated below is the M-200 Model with SAE8 ports.

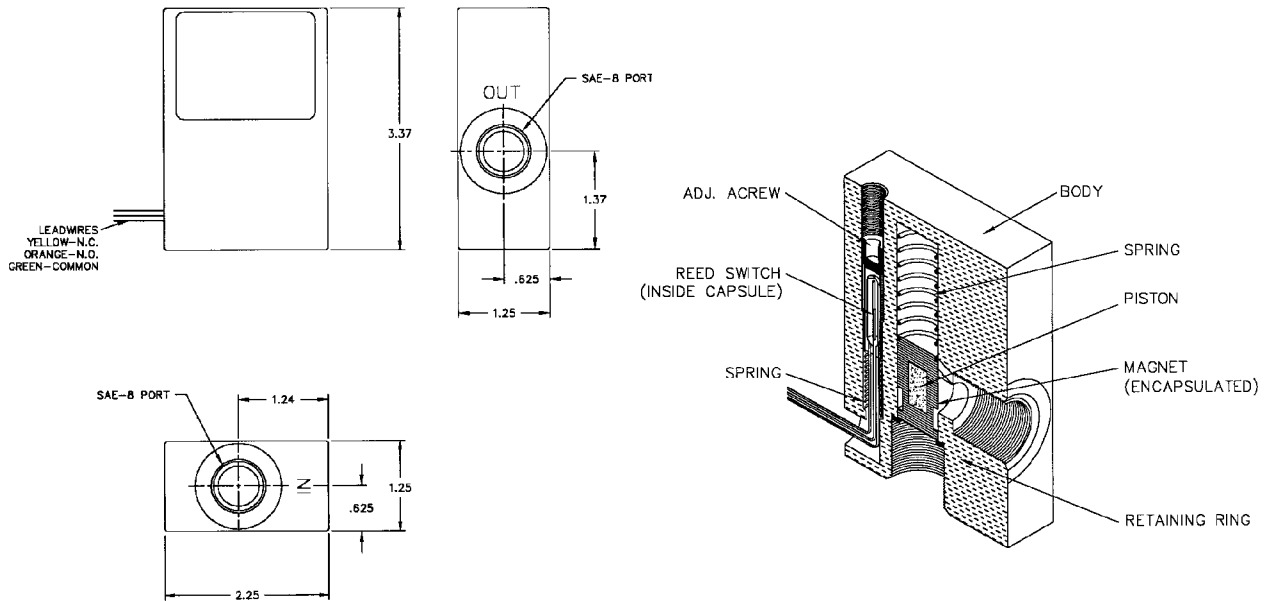

\* Note: The M-200 Model with SAE8 ports is only available in Brass and 316 Stainless Steel

## Factory Preset Information

The M-200 is an adjustable flow switch. The flow set point can be set at the factory, upon request. Proper calibration of the set point requires the following information. When purchasing a flow switch that needs to be factory preset, use the "Set Point Calibration" form on page i-vi or provide this information on the purchase order.

- Calibration set point,
- Increasing or decreasing flow,
- Fluid type (i.e. liquid or gas),
- Density or specific gravity,
- Viscosity,
- System pressure and temperature,
- Flow direction (i.e. upward or downward), and
- Mounting orientation (i.e. horizontal or vertical).

## Ordering Information

Standard Part Numbering						
M	-	Model	-	Material	Port	Switch
M	-	200	-	S	3	1
		200		A - Aluminum B - Brass P - Acrylic S - 316 Stainless T - PTFE	3 - 3/8" 4 - 1/2" 6 - 3/4"	1 - SPST N.O. 3 - SPDT

\* The M-200 with 3/4" ports is ONLY available in the Brass, PTFE or 316 SS body material.  
The M-200 in Brass or 316 Stainless Steel is also available with SAE 8 ports.