

RACK AND PINION

ACTUATORS AND ACCESSORIES

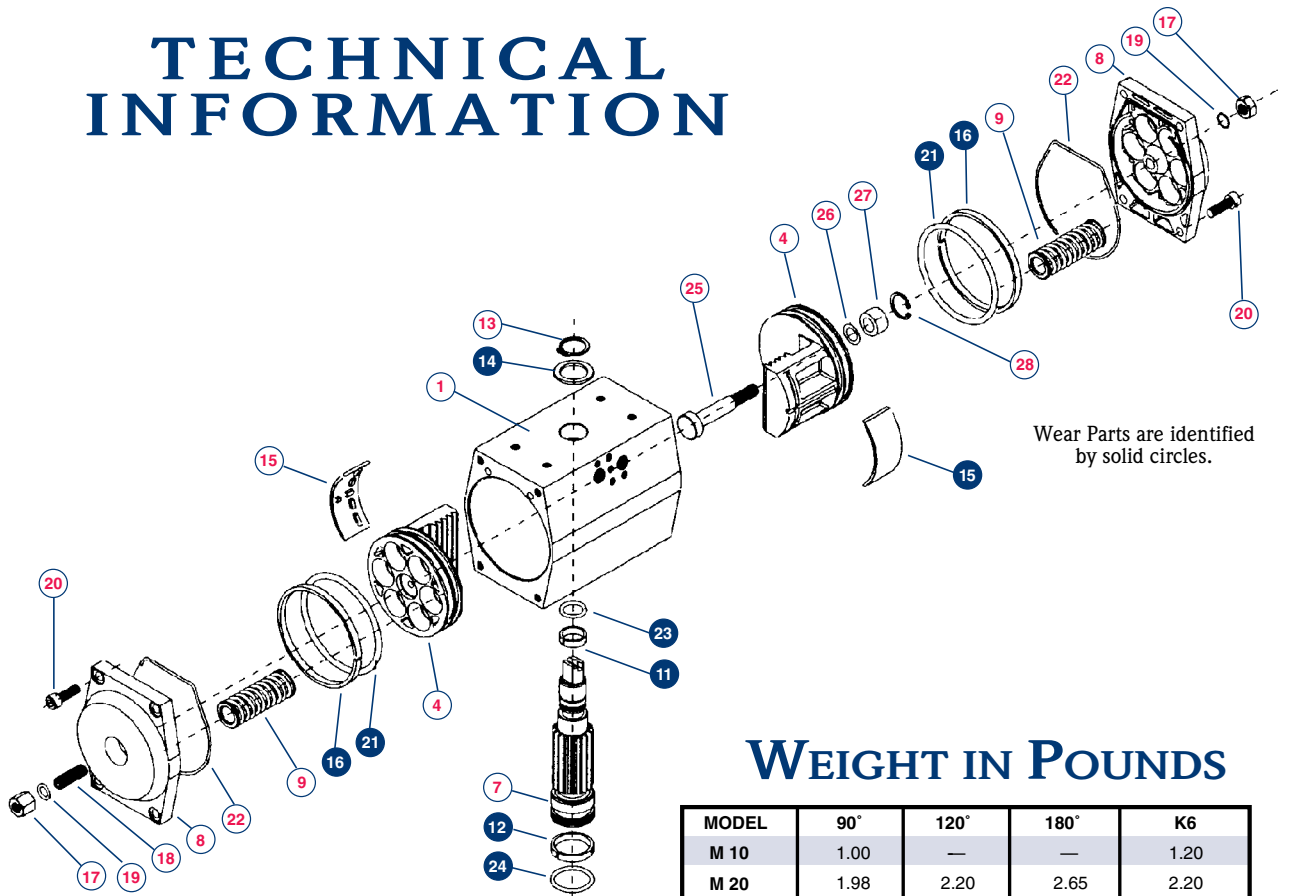

TECHNICAL INFORMATION



Wear Parts are identified by solid circles.

M-SERIES MATERIALS

POS.	QTY.	DESCRIPTION	MATERIAL
1	1	BODY	ANODIZED ALUMINUM POLYESTER EPOXY COATING
4	2	PISTON**	DIE CAST ALUMINUM
7	1	PINION	E.N.P. ASTM B656 STEEL
8	2	END CAP**	EPOXY COATED ALUMINUM
9	MAX 12	SPRING CARTRIDGE	EPOXY COATED STEEL DELRIN / BRASS
11	1	UPPER PINION BEARING	DELRIN 500
12	1	LOWER PINION BEARING	DELRIN 500
13	1	CIRCLIP	E.N.P. ASTM B656 STEEL
14	1	PINION WASHER	DELRIN 500
15	2	PISTON SKATE	DELRIN 500
16	2	PISTON GUIDE RING	DELRIN 500
17	2	SEALING NUT	304 Stainless Steel
18	2	TRAVEL STOP	304 Stainless Steel
19	2	TRAVEL STOP O-RING	BUNA N
20	8	END CAP SCREW	304 Stainless Steel
21	2	PISTON O-RING	BUNA N
22	2	END CAP O-RING	BUNA N
23	1	UPPER PINION O-RING	BUNA N
24	1	LOWER PINION O-RING	BUNA N
25	1	DLS STOP BOLT	304 STAINLESS STEEL
26	1	DLS STOP BOLT O RING	VITON
27	1	DLS STOP BOLT BEARING	TEFLON
28	1	DLS STOP BOLT CIRCLIP	E.N.P. ASTM B656 STEEL

WEIGHT IN POUNDS

MODEL	90°	120°	180°	K6
M 10	1.00	—	—	1.20
M 20	1.98	2.20	2.65	2.20
M 30	2.98	3.26	3.97	3.42
M 52	4.30	4.74	5.95	5.07
M 73	5.51	5.95	7.94	6.39
M 103	7.39	8.16	11.25	8.38
M 148	10.58	11.47	13.56	12.79
M 222	14.99	16.90	20.68	17.86
M 295	18.74	20.73	26.02	22.49
M 470	31.00	—	—	39.80
M 586	34.40	39.69	55.79	42.78
M 900	61.50	—	—	83.10
M 1213	68.80	81.14	106.94	86.66
M 2366	132.32	146.63	173.60	180.81
M 2958	160.97	177.60	—	209.48
M 3720	205.00	—	—	267.00

AIR CONSUMPTION CUBIC INCHES PER CYCLE (Open/Close)

MODEL	90°	120°	180°	K6
M 10	12.8	—	—	6.7
M 20	15.3	17.1	28.1	7.3
M 30	22.0	24.4	41.5	9.2
M 52	36.6	42.7	68.3	15.3
M 73	52.5	61.0	99.5	22.0
M 103	67.1	82.4	131.2	27.5
M 148	112.9	137.3	189.2	41.5
M 222	152.6	176.9	341.7	67.1
M 295	218.5	241.0	415.0	86.7
M 470	335.6	—	—	174.5
M 586	416.2	476.0	790.2	174.5
M 900	762.8	—	—	396.7
M 1213	872.6	1013.0	1293.7	360.0
M 2366	1586.6	1861.2	2471.5	701.8
M 2958	1922.2	2288.4	—	1037.4
M 3720	2955.0	—	—	1594.0

** M10 - M20 utilize polyamide materials

Unitorq Pneumatic Actuator Torque Chart

The Following Torque Values Are in IN.-LB. And Represent Air Stroke For The Spring Return Unit.

PSI	40	60	80	100	120		ALL	40	60	80	100	120						
	DOUBLE ACTING TORQUE in lbs.					K#	SPRING Start End	AIR		AIR		AIR		AIR				
M10	50	75	100	125	150	2	56 56	—	11	18	35	42	60	67	85	92	110	
	—	—	—	—	—	3	83 83	—	—	—	16	15	40	40	65	65	90	
M20	102	152	203	254	305	2	56 38	44	62	94	112	144	162	194	212	244	262	
	—	—	—	—	—	3	83 57	15	42	65	92	115	142	165	192	215	242	
	—	—	—	—	—	4	111 76	—	22	36	72	86	122	136	172	186	222	
	—	—	—	—	—	5	139 95	—	2	6	52	56	102	106	152	156	202	
M30	151	227	302	378	453	2	80 56	69	93	144	168	218	242	293	317	367	391	
	—	—	—	—	—	3	119 83	30	66	104	140	179	215	253	289	328	364	
	—	—	—	—	—	4	159 111	—	38	64	112	139	187	213	261	288	336	
	—	—	—	—	—	5	199 139	—	10	24	84	99	159	173	233	248	308	
	—	—	—	—	—	6	239 167	—	—	56	59	131	133	206	208	280	280	
	—	—	—	—	—	2	154 104	105	155	235	285	365	415	494	545	624	675	
M52	263	395	526	658	789	2	232 156	28	103	158	233	287	363	417	493	547	623	
	—	—	—	—	—	4	309 208	—	51	80	181	210	311	340	441	469	570	
	—	—	—	—	—	5	386 260	—	—	3	129	132	259	262	388	392	518	
	—	—	—	—	—	6	463 312	—	—	76	55	206	185	336	314	466	466	
M73	367	551	734	918	1101	2	199 127	163	235	344	417	525	598	706	779	887	960	
	—	—	—	—	—	3	299 190	63	172	244	353	426	534	607	715	788	896	
	—	—	—	—	—	4	398 253	—	108	145	290	326	471	507	652	688	833	
	—	—	—	—	—	5	498 317	—	45	45	226	226	407	407	588	588	769	
M103	516	774	1032	1290	1548	2	267 189	241	318	495	572	749	826	1002	1080	1256	1334	
	—	—	—	—	—	3	400 284	107	223	361	477	615	731	869	985	1123	1239	
	—	—	—	—	—	4	533 379	—	128	227	382	481	636	735	890	989	1144	
	—	—	—	—	—	5	667 473	—	33	93	287	347	541	601	795	855	1049	
	—	—	—	—	—	6	800 568	—	—	192	213	446	467	700	721	954	954	
	—	—	—	—	—	2	407 260	321	468	685	832	1049	1196	1413	1560	1777	1924	
M148	740	1109	1479	1849	2219	2	611 391	117	337	481	701	845	1065	1209	1429	1573	1793	
	—	—	—	—	—	4	814 521	—	207	277	571	641	935	1005	1299	1369	1663	
	—	—	—	—	—	5	1018 651	—	76	73	440	437	804	801	1168	1165	1532	
	—	—	—	—	—	6	1221 781	—	—	309	232	673	596	1037	960	1401	1401	
M222	1109	1664	2218	2773	3327	2	550 400	489	645	1018	1174	1548	1704	2077	2233	2607	2763	
	—	—	—	—	—	3	826 600	188	426	718	956	1247	1485	1777	2015	2307	2544	
	—	—	—	—	—	4	1101 800	—	200	407	729	936	1259	1466	1789	1995	2318	
	—	—	—	—	—	5	1376 1000	—	—	84	495	614	1025	1144	1554	1673	2084	
	—	—	—	—	—	6	1651 1200	—	—	253	281	783	810	1312	1340	1842	1842	
M295	1479	2219	2958	3698	4437	2	814 516	641	939	1369	814	2097	2395	2825	3123	3552	3850	
	—	—	—	—	—	3	1222 775	234	681	962	1222	1689	2137	2417	2864	3145	3592	
	—	—	—	—	—	4	1629 1033	—	423	554	1629	1282	1878	2010	2606	2738	3334	
	—	—	—	—	—	5	2036 1291	—	164	147	2036	874	1620	1602	2348	2330	3075	
M470	2071	3106	4142	5177	6213	2	1133 681	938	1390	1974	2425	3009	3461	4045	4496	5080	5532	
	—	—	—	—	—	3	1699 1022	371	1049	1407	2084	2443	3120	3478	4155	4514	5191	
	—	—	—	—	—	4	2266 1363	—	708	840	1743	1876	2779	2911	3841	3947	4850	
	—	—	—	—	—	5	2832 1704	—	367	273	1402	1309	2438	2344	3473	3380	4509	
	—	—	—	—	—	6	3398 2044	—	26	—	1061	742	2097	1777	3132	2813	4168	
M586	2933	4399	5865	7331	8798	2	1542 1052	1344	1834	2787	3277	4320	4720	5673	6163	7117	7606	
	—	—	—	—	—	3	2312 1578	573	1308	2016	2751	3459	4194	4902	5637	6345	7080	
	—	—	—	—	—	4	3083 2104	—	781	1245	2224	2688	3667	4131	5111	5574	6554	
	—	—	—	—	—	5	3854 2630	—	255	473	1698	1916	3141	3359	4584	4802	6027	
M900	4550	6825	9100	11375	13650	2	2251 1619	2227	2859	4466	5098	6705	7337	8944	9576	11183	11815	
	—	—	—	—	—	3	3376 2428	1101	2049	3340	4288	5579	6527	7818	8766	10057	11005	
	—	—	—	—	—	4	4501 3238	—	1239	2214	3478	4453	5717	6692	7956	8931	10195	
	—	—	—	—	—	5	5627 4047	—	429	1088	2668	3327	4907	5566	7146	7805	9385	
M1213	6066	9099	12132	15165	18198	2	3000 2159	2969	3811	5954	6796	8939	9781	11924	12766	14910	15751	
	—	—	—	—	—	3	4501 3238	1468	2731	4453	5716	7438	8701	10424	11686	13409	14672	
	—	—	—	—	—	4	6001 4317	—	1651	2952	4636	5937	7621	8922	10606	11907	13591	
	—	—	—	—	—	5	7501 5397	—	571	1451	3556	4436	6541	7421	9526	10406	12511	
	—	—	—	—	—	6	9001 6476	—	—	2475	2934	5460	5919	8446	8904	11431	11431	
	—	—	—	—	—	2	6832 4573	4812	7072	10635	12895	16457	18718	22280	24540	28103	30363	
M 2366	11833	17749	23665	29581	35498	3	10249	6859	1394	4785	7217	10607	13040	16430	18862	22253	24685	28076
	—	—	—	—	—	4	13665	9145	—	2497	3798	8319	9621	14142	15444	19965	21267	25788
	—	—	—	—	—	5	17081	11432	—	208	379	6031	6202	11854	12025	17677	17847	23499
	—	—	—	—	—	6	20497	13718	—	—	3742	2782	9565	8605	15388	14427	21210	21210
M 2958	14790	22186	29581	37250	44371	2	8540	5015	6015	9541	13293	16819	20571	24097	27850	31376	35128	38654
	—	—	—	—	—	3	12811	7523	1742	7032	9021	14310	16299	21589	23577	28867	30856	36145
	—	—	—	—	—	4	17081	10030	—	4523	4748	11801	12026	19079	19304	26358	26583	33636
	—	—	—	—	—	5	21351	12538	—	2013	474	9291	7752	16570	15030	23848	22309	31126
M 3720	18625	27938	37250	47250	55875	2	8148	5119	11098	14127	20721	23750	30345	33374	39968	42997	49592	52621
	—	—	—	—	—	3	12222	7679	7022	11566	16645	21189	26269	30813	35892	40436	45516	50060
	—	—	—	—	—	4	16296	10239	2945	9004	12568	18628	22192	28251	31816	37875	44139	47498
	—	—	—	—	—	5	20370	12799	—	6442	8491	16066	18114	25689	27738	35313	37362	44936
	—	—	—	—	—	6	24443	15358	—	3880	4413	13503	14036	23127	23660	32750	33283	42374
	—	—	—	—	—	7	28517	17918	—	1317	333	10940	9957	20564	19580	30187	29204	39811
	—	—	—	—	—	8	32591	20478	—	—	—	8377	5877	18000	15500	27624	25124	

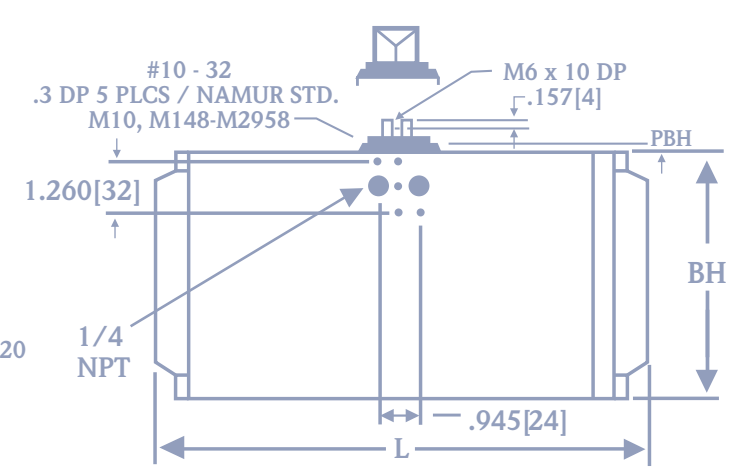
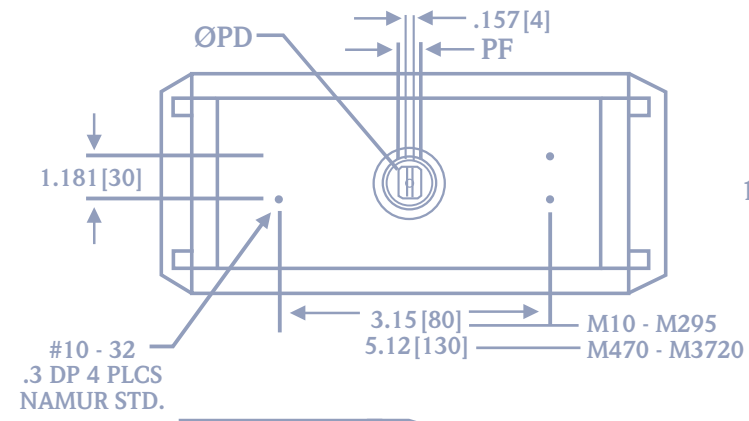
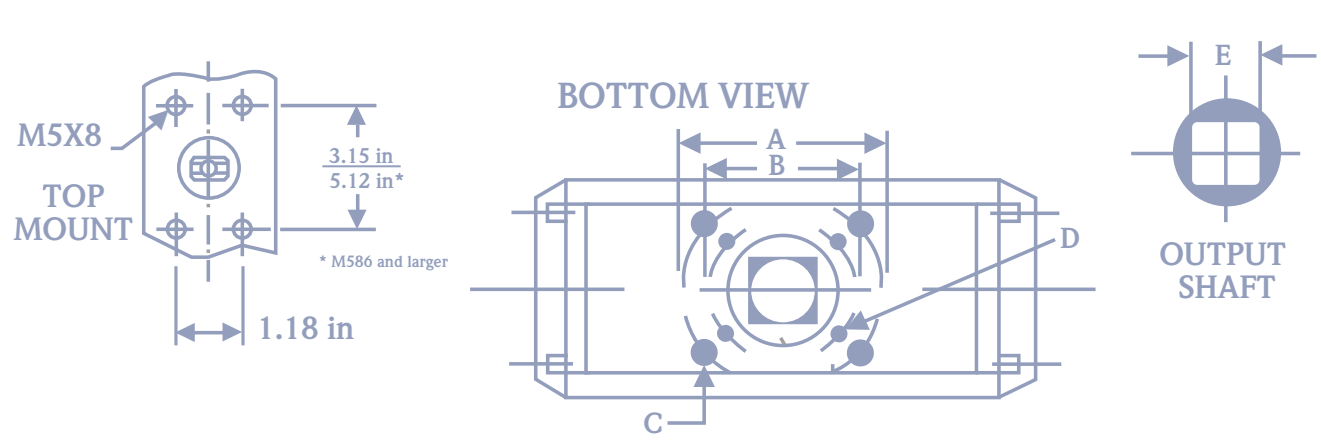

Model	A	FO	B	FO	C*	D*	E	F	G	H	I	L	L1*	M	N	P	Q	R	S
M 10	1.65	F04	1.42	F03	#10 - 32	#10 - 32	9 or 11MM	0.55	2.02	2.54	0.35	4.33	—	0.48	—	2.60	3.50	1/4	.94
M 20	1.97	F05	1.42	F03	1/4 - 20	#10 - 32	14MM	0.71	1.97	2.32	0.39	5.00	7.52	0.47	0.79	2.91	3.82	1/4	.94
M 30	2.76	F07	1.97	F05	5/16 - 18	1/4 - 20	14MM	0.71	2.36	2.76	0.39	5.24	7.99	0.47	0.79	3.46	4.37	1/4	.94
M 52	2.76	F07	1.97	F05	5/16 - 18	1/4 - 20	17MM	0.75	2.56	3.27	0.39	6.10	9.29	0.55	1.02	3.94	4.84	1/4	.94
M 73	2.76	F07	1.97	F05	5/16 - 18	1/4 - 20	17MM	0.75	2.56	3.58	0.39	6.97	10.63	0.55	1.02	4.25	4.95	1/4	.94
M 103	2.76	F07	1.97	F05	5/16 - 18	1/4 - 20	17MM	0.75	2.76	3.94	0.55	7.99	12.36	0.79	1.38	4.61	5.55	1/4	.94
M 148	4.02	F10	2.76	F07	3/8 - 16	5/16 - 18	22MM	0.96	3.54	4.72	0.55	8.50	12.72	0.79	1.97	5.51	6.45	1/4	.94
M 222	4.02	F10	2.76	F07	3/8 - 16	5/16 - 18	22MM	0.96	3.54	4.72	0.79	11.18	16.85	1.10	1.97	5.51	6.71	1/4	.94
M 295	4.02	F10	2.76	F07	3/8 - 16	5/16 - 18	22MM	0.98	4.06	5.39	0.79	11.42	17.76	1.10	1.97	6.30	7.51	1/4	.94
M 470	4.92	F12	4.02	F10	1/2 - 13	3/8 - 16	27MM	1.07	4.33	6.77	0.79	13.27	—	1.10	2.36	7.80	9.70	1/4	.94
M 586	4.92	F12	4.02	F10	1/2 - 13	3/8 - 16	27MM	1.07	4.33	6.77	1.10	14.49	22.36	1.42	2.36	7.80	9.70	1/4	.94
M 900	6.50	F16	4.92	F12	3/4 - 10	1/2 - 13	36MM	1.57	5.31	8.82	1.26	16.62	—	1.42	2.84	10.00	11.77	1/4	.94
M 1213	5.51	F14	—	—	5/8 - 11	—	36MM	1.57	5.31	8.82	1.26	17.72	27.24	1.57	2.95	10.00	11.77	1/4	.94
M 2366	6.50	F16	—	—	3/4 - 10	—	46MM	1.57	6.26	10.71	1.26	23.07	35.63	1.57	3.54	11.89	13.66	1/4	.94
M 2958	6.50	F16	—	—	3/4 - 10	—	46MM	1.53	6.26	10.71	1.26	23.07	—	1.57	3.54	11.89	13.66	1/4	.94
M 3720	6.50	F16	—	—	3/4 - 10	—	46MM	1.61	6.30	14.17	1.26	26.89	—	1.58	2.96	14.17	15.94	1/2	1.97

Top mounting dimensions for accessories to Namur standard. Bottom mounting is to DIN-ISO standards.
Solenoid mounting to Namur specifications is available on all units and is standard on units 148 and higher.
* U.N.C. bolt sizes.
L1* - 180° end-to-end dimensions

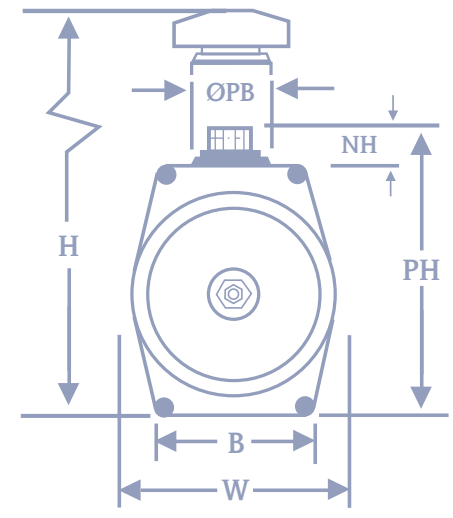
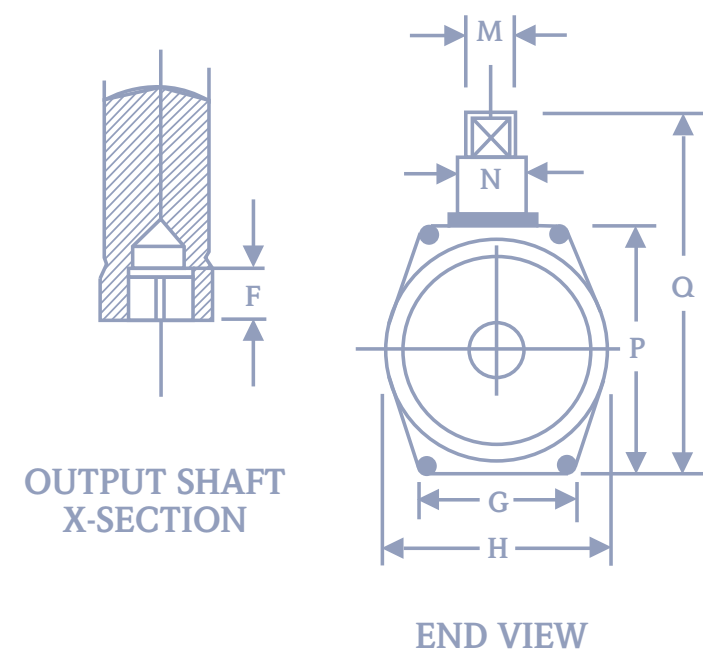
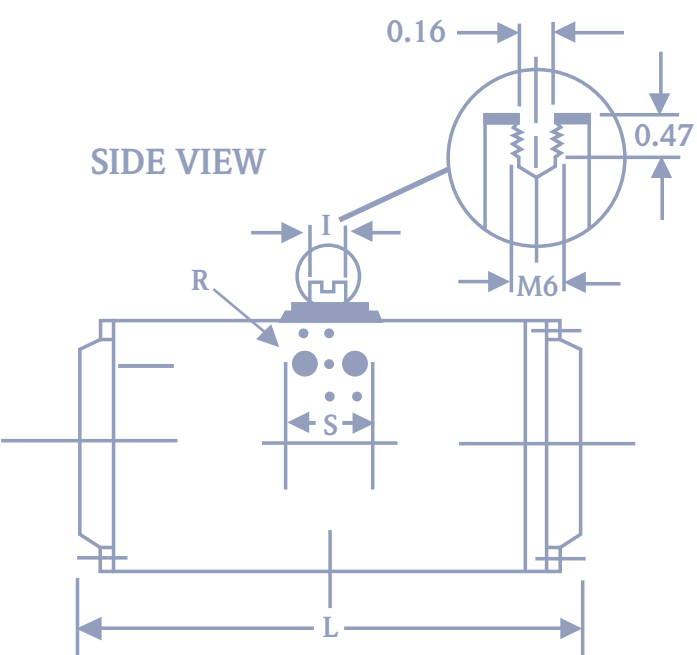

MOUNTING DIMENSIONS

SIZE	ISO		
	X	Y	Z
M10	F03	—	—
M10	—	F04*	—
M20	F03	F05	—
M30	F05	F07	—
M52	F05	F07	—
M73	F05	F07	—
M103	F05	F07	—
M148	F07	F10	—
M222	F07	F10	—
M295	F07	F10	F12
M470	—	F10	F12
M586	—	F10	F12
M900	—	F12	F16'
M1213	—	—	F14
M2366	—	—	F16
M2958	—	—	F16
M3720	—	—	F16

DRIVE DIMENSIONS

SIZE	ISO SQUARE 8 - POINT							
	A mm	A in.	A'	øB	øC	C'	øD	D'
M10	9	0.354	0.55	0.673	0.85	0.09	—	—
M10	11	0.433	0.55	0.673	0.85	0.09	—	—
M20	14	0.551	0.61	0.713	0.92	0.08	0.60	0.71
M30	14	0.669	0.61	0.713	0.92	0.08	0.60	0.71
M52	17	0.669	0.63	0.874	1.13	0.08	0.73	0.81
M73	17	0.669	0.63	0.874	1.25	0.08	0.73	0.81
M103	17	0.669	0.63	0.874	1.45	0.08	0.73	1.14
M148	22	0.866	0.81	1.122	1.57	0.10	0.94	1.03
M222	22	0.866	0.81	1.122	2.07	0.10	0.94	1.26
M295	22	0.866	0.83	1.122	2.07	0.12	0.94	1.30
M470	27	1.063	0.83	1.437	2.59	0.12	1.15	1.69
M586	27	1.063	0.83	1.437	2.59	0.12	1.15	1.69
M900	30	1.417	1.26	1.909	3.10	0.16	1.56	2.17
M1213	36	1.417	1.26	1.909	3.10	0.16	1.56	2.17
M2366	46	1.811	1.26	2.441	4.12	0.16	2.00	2.13
M2958	46	1.811	1.22	2.441	5.12	0.12	2.00	2.09
M3720	48	1.811	1.26	2.441	5.12	0.12	2.00	2.13

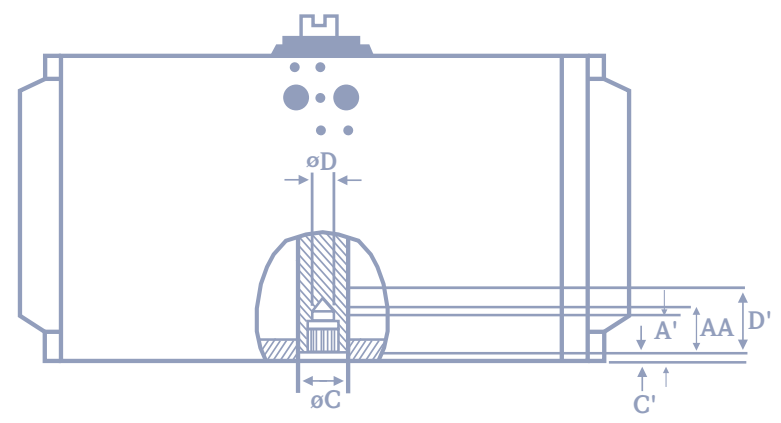

ISO MOUNTING PATTERN TABLE

ISO	øB.C.	øB.C.	THREAD	DP
	in.	mm		
F03	1.417	36	#10 - 32UNC	0.43
F04*	1.654	42	#10 - 32UNC	0.43
F05	1.969	50	1/4 - 20UNC	0.35
F07	2.758	70	5/16 - 16UNC	0.47
F10	4.016	102	3/8 - 16UNC	0.59
F12	4.921	125	1/2 - 13UNC	0.71
F14	5.512	140	5/8 - 11UNC	0.94
F16	6.496	165	3/4 - 10UNC	1.18

' M900 has 5/8" - 11UNC on F16
' M3720 also includes a 4.59 x 12.87 rectangular pattern
* Alternate Bottom Plate (M10 Only)

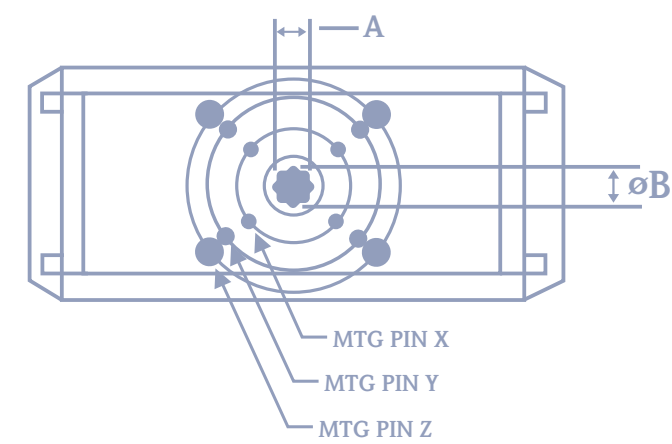



UniTorq

Established in 1992 in Norcross, Georgia, UniTorq has consistently provided our customers with reliable, affordable actuators and accessories. With a continued focus on the latest trends in technology and manufacturing, we have expanded our product line to include a wider selection of sizes and features to meet the varying needs in today's market. These changing market trends have lead to the introduction of an electric line of actuators in 1999 along with an expanded product line of pneumatic actuators and accessories. At UniTorq, the basic principle is continuous dedication to our customers' needs through the manufacturing and distribution of superior actuation products with an ongoing commitment to dependable service and support.

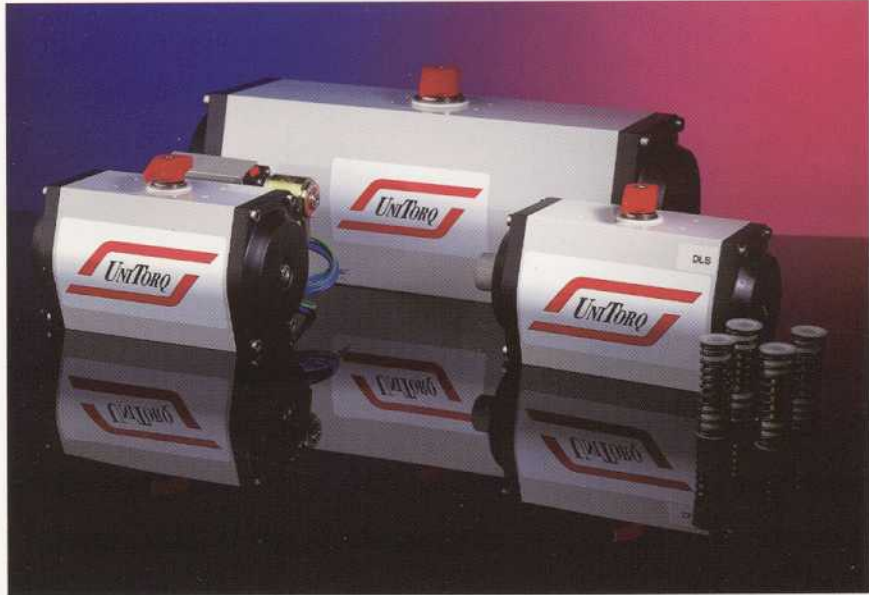

UNITORQ — HOW TO SPECIFY

Actuator will be a dual rack and pinion design with a one piece electroless nickel plated pinion that is machined a continuous 360 degrees and drive dimensions to ISO 5211 dimensions. The pinion shall have upper and lower Delrin 500 encapsulated bearings. The actuator body shall be of extruded aluminum, hard anodized after machining and then painted with a one part dry powder epoxy polyester paint for additional external protection. End caps shall be aluminum die cast with one part dry powder epoxy polyester for protection. End caps shall be affixed to the body with stainless steel UNC cap screws. Actuator will have as standard double travel stops that can be adjusted while the actuator is pressurized. Actuator shall have Delrin 500 piston bearings permanently affixed to the pistons, all seals on the end caps, and pinions shall be Buna N material. Actuator shall have the capability of being field converted from double acting to spring return type with no additional tooling required. The actuator shall have the same end-to-end dimensions for double acting as spring return. Spring design shall be of the fully encapsulated design for safety. All dimensions shall be to Namur for the affixing of accessories and transmitting devices. All mounting dimensions to the valve or damper shall be to ISO 5211 standard. All actuators shall be fully traceable by an individual serial number permanently stamped on the body. This actuator shall be designated as the UniTorq "M" Series actuator.

*For additional information regarding our products,
or to place an order, please phone our office.
UniTorq can also be reached via the web at*

www.unitorq.com

Unitorq Actuators & Controls

2825 Pacific Drive • Norcross, Georgia 30071
Tel: 770.446.7074 • Fax: 770.447.1825