

AN ISO 9001
REGISTERED COMPANY

Series 51/52 Flanged Ball Valves

*Standard and Anti-Static Valves
in ANSI Class 150 and 300*

Series 51/52 Flanged Ball Valves

Designed to Automate, Control, Contain and Shut Off Your Process

Flowserve's Series 51/52 is a standardized line of flanged ball valves in sizes ½"–10" with flange ratings of ANSI Class 150 and 300. The combination of elements of this standardization provides a manually operated or automated valve which exceeds the production requirements of your process. Such requirements include high-cycle operation, pressure integrity, material compatibility, speed of operation, automatic control and high temperature endurance.

Tight Shutoff

Series 51/52 valves are two-way flow ball valves designed to seal bi-directionally against resilient seats. The ball is forced downstream under pressure against the downstream seat to effect and maintain a seal. The resiliency of the seats is a result of design as well as the characteristics of materials used. Consequently, the valve will give bubble-tight shutoff throughout a long service life. The seats are also designed to perform a wiping action during each cycle. This wiping action cleans foreign materials off both the seat and ball, assuring leak-tight sealing.

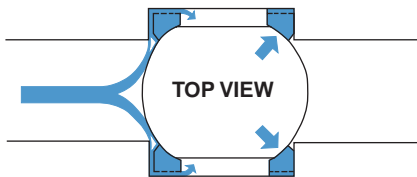

A pair of patented seats with relief slots makes downstream sealing possible. The result is less friction, lower operating torque, less seat wear, and longer service life. The patented seats also permit the valve to operate at a higher pressure differential with lower torques than double-sealing valves in which there is sealing between both seats and the ball.

Downstream sealing prevents seat damage and lowers operating torque while providing full bidirectional capability. The Flowserve design results in smoother, more efficient valve operation.

Leak-Tight Stem Design

Flowserve's Series 51/52 valves outperform globe and gate valves. Not only are they easier to automate, best of all, they won't leak as sliding stem valves often do. The no-leak rotary stem seal features a bottom-entry, adjustable, self-compensating stem design. A hole in the ball's stem slot prevents any possibility of damage due to trapped cavity pressure when the ball is open. The stem seal package consists of one or two thrust washers and one or a series of stem seal rings, depending on valve size. On ½"–2" valves, a pair of Belleville washers acts as a spring to compensate for wear and thermal expansion. On larger valves, the deep stuffing box with additional packing provides resiliency.

Performance to Match Your Process

A wide variety of body, seat and seal materials coupled with advanced seat technology means dependable, high-cycle control on steam, petroleum products, chemicals, and abrasive liquids.

Series 51/52 flanged ball valves are used for manual on/off operation with lever handles or gear operators. They are also easy to automate pneumatically or electrically, as detailed on page 3. In addition, these valves can be very flexible in operation. You can open and close them as frequently as necessary and at any speed you choose. Closing too rapidly, however, may cause pressure shock (hammer) in the piping system.

As for special applications, Flowserve can provide flanged valves to handle them. Special applications include toxic chemicals, cryogenics, viscous fluids, vacuum sealing, chlorine, steam and high-cycle production.

For the Series 51/52 solution to your control problems, contact your local Worcester Controls stocking distributor or area sales manager.



- One-Piece Body Construction
- High-Cycle Stem Seals
- Compact, Safe, Blowout-Proof Stem
- Smooth, Two-Way Flow Path
- Patented Seat Design Downstream Sealing
- Separate Body Seal
- 150# or 300# ANSI Flanges
- Pre-Drilled Mounting Pad For Actuation



Fire Rated Valves

In recent years, many factors have contributed to an increased demand for fire-safe valves. Engineers and plant managers have faced the rising cost of insurance against liability and property damage. There has been an across the board tightening of environmental and safety regulations.

Special models of Flowserve's Series 51/52 flanged ball valves meet virtually all fire safety standards for structural integrity and external and through-valve shutoff:

- API 607 Edition 4
- BS-5351 – Anti-Static
- FM 7440 – Fire-Safe Valves
- EXES 3-14-1-2A (Fire-Safe)

Refer to brochure WCABR1029 for technical data and applicable sizes and Series numbers.



Automation Pneumatic, Electric and Computer-Compatible Controls

Easy modulating or on/off automation is assured by our Series 39 pneumatic or Series 75 electric actuators.

Both are backed by our exclusive two-year warranty. The Series 39 actuator is the toughest and most reliable rotary actuator available. Also available with positioners (including the new Pulsair® loop-powered positioner, shown opposite), that provides accurate control for your system. Refer to brochures WCABR1003 and WCABR1018.

Mount a Series 75 electric actuator and you have a high-performance automated valve package specifically designed for computer or PLC control. For proportional control, the Series 75 can be operated by pulses or with an analog signal. A variety of options allow you to select the performance criteria and feedback information you desire. The Series 75 is available with TYPE 1, 4, 7 or 9 enclosures. Refer to brochure WCABR1014.

For automated on/off applications, Flowserve offers two other lines of actuators, the Series 34 Scotch yoke pneumatic actuator and the Series 72 Electri-SAFE™ fail-safe electric actuator (see back page). For actuator/valve sizing information, see brochure WCASS0001.

The Standards

EXES 3-14-1-2A is a petroleum company's Fire Test. Flowserve's line of FZ Fire Rated Ball Valves meet this standard. The AF 51/52 Valves do not.

API 6D approval has been granted to Flowserve for 2"–8" carbon steel and stainless steel flanged valves. These valves meet the American Petroleum Institute's rigid requirements. Available as an option by specifying V 39 when ordering. Certification is available upon request. Available on Series 51/52 and AF 51/52.

NACE MR-01-75, a material standard developed by the National Association of Corrosion Engineers, requires that metallic components of oil field equipment exposed to sour environments be sulfide stress cracking (SSC) resistant. Prevention of SSC is assured by proper selection of materials of controlled composition and hardness. Available on Series 51/52 and AF 51/52.

API 607 Edition 4 is a fire test for soft seated valves, developed by the Refinery Division of the American Petroleum Institute (API). This standard measures the ability of a ball valve in the closed position to retard fire propagation. Valves meeting API 607 are designed to inhibit and control fires that are fueled by volatile fluids. Series FZ 51/52 valves meet this standard.

Features and Benefits

Sizes: 1/2", 3/4", 1", 1 1/2", 2", 3", 4", 6", 8", 10"

Flanges: Series 51 – ANSI 150#
Series 52 – ANSI 300#

Body Materials: Cast Carbon Steel to ASTM A216 Grade WCB
Cast Stainless Steel to ASTM A351 Grade CF8M (316)
Ductile Iron to ASTM A536 (Series 51 3"-8" only)

Thrustbearing: (1/2"-2" only) Polyfill® or UHMWPE
(3"-10" only) 25% glass filled TFE

Stem: One-piece bottom-entry design. 316 S.S. stem available with all body materials and sizes. Alloy 20® (through 4"), Monel® (through 8"), Hastelloy® C (through 8")

Stem Seals: (1/2"-2") Polyfill or UHMWPE
(3"-10") 15% glass filled TFE

Seats*: TFE, Reinforced TFE, Polyfill and UHMWPE

Body Seals: TFE, Buna (through 8"), Viton® (through 8"), Graphite (3"-10"), EPR (1/2"-2"), 316 "S" Gasket (1/2"-2"), UHMWPE (1/2"-8")

Ball: 316 S.S., Monel (through 8"), Alloy 20 (through 4"), Hastelloy C (through 8")

End Plug: Retention bolt style (3"-10"), threaded style (1/2"-2")

Operation: 1/2"-8" with handle. 10" supplied without handle. For use with gear operators and electric or pneumatic actuators.

Standards: ANSI B16.10, face-to-face dimensions
ANSI B16.5, 150# and 300# flange dimensions
MSS SP-72, ball valves for general service
NACE MR-01-75, Pipeline valve standard for sour gas service (1/2"-8" only).
API 6D, Pipeline valves (2"-8" carbon steel and stainless steel). Specify V-39 option.
ANSI B16.34.
MSS SP6 flange finish (125-250 Ra)
Factory Mutual Approval for Oil & Gas Safety Shutoff. Consult Flowserve.

NOTE: Certifications to above standards are available upon request. Specify when ordering.

*For metal seats, refer to brochure WCABR1030.

Pressure/Temperature Rating

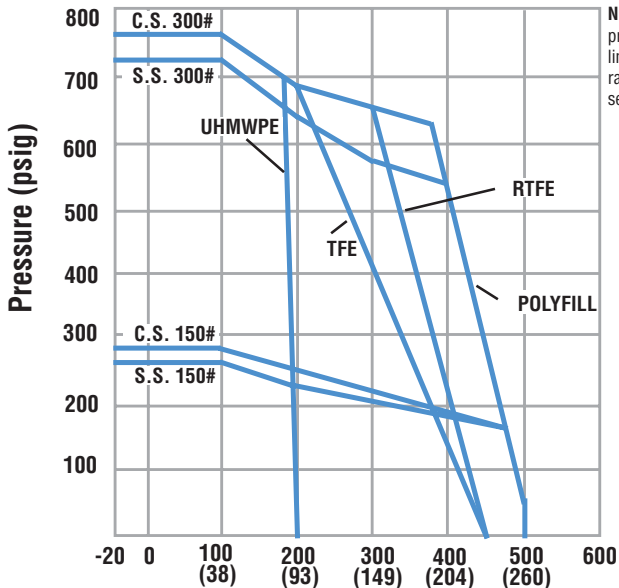

NOTE: Max. working pressure/temperature limited by both flange rating, seat and body seal capability.

C_v Data

| Valve Size | C _v | Equiv. Length of Sched. 40 pipe, feet |
|------------|----------------|---------------------------------------|
| 1/2" | 8 | 3.9 |
| 3/4" | 12 | 8.7 |
| 1" | 32 | 3.6 |
| 1 1/2" | 82 | 3.7 |
| 2" | 120 | 6.5 |
| 3" | 350 | 7.1 |
| 4" | 720 | 6.9 |
| 6" | 1020 | 20.4 |
| 8" | 1800 | 37.7 |
| 10" | 2970 | 42.6 |

Variation (V-Numbered Options)

- | | | | |
|------|--|------|--|
| V 3 | Upstream Relief Hole | V 37 | Certificate of Compliance & Hydro Testing |
| V 5 | Hydrostatic Testing | V 39 | API-6D Approved Valves (2"-8") |
| V 6 | Source Inspection | V 46 | Silicone Free Lubricant |
| V 14 | Handleless Valves (3"-8") | V 48 | Extended Lever Handle (1/2"-2") |
| V 17 | Grounding Thrust Bearing | V 51 | High Cycle Stem Build (3"-8") |
| V 20 | Oxygen Service (1/2"-2") | V 58 | B16.34 Compliance |
| V 32 | Oval Handle (1/2"-2") | V 59 | Extended Oval Handle (1/2"-2") |
| V 33 | Oxygen Service w/o Source Inspect. (1/2"-2") | V 66 | Certificate of Compliance for European Valve Orders |
| V 34 | 51/52 Threaded End Plug (3"-8") | V 72 | Cert. of Comp. for European Pressure Equipment Directive Conformance |
| V 36 | Certificate of Compliance | | |

Dimensions – inches (mm) — See Page 6 for Class 150 and 300 flange dimensions

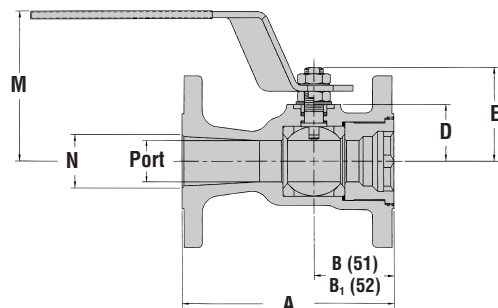

1/2"–2"
Threaded End Plug Retention

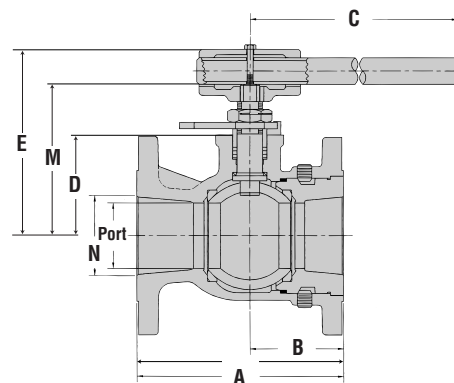
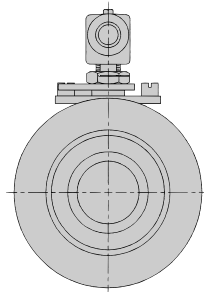

3"–10"
(shown with antistatic option 3"–10" AF 51/52 only)
Bolted End Plug Retention
(Threaded Retention available)

| Valve Size | 51, AF51 52, AF52 | | | | | | | | | | Weight lb. (kg) | |
|------------|-------------------|------------------|------------------|-----------------|----------------|-----------------|-----------------|------------------|------------------|------------------|-----------------|----------------|
| | Port | A | A | B | B ₁ | C | D | E | M | N | 51/AF51 | 52, AF52 |
| 1/2" | .44 (11.2) | 4.25 (108.0) | 5.50 (139.7) | 1.81 (46.0) | 2.31 (58.7) | 5.53 (140.5) | .94 (23.9) | 1.55 (39.4) | 2.88 (73.2) | .59 (15.0) | 4.5 (2.0) | 5.5 (2.5) |
| 3/4" | .56 (14.2) | 4.62 (117.4) | 6.00 (152.4) | 1.94 (49.3) | 2.44 (62.0) | 5.53 (140.5) | 1.03 (26.2) | 1.64 (41.7) | 2.98 (75.7) | .83 (21.1) | 6.6 (3.0) | 7.5 (3.4) |
| 1" | .81 (20.1) | 5.00 (127.0) | 6.50 (165.1) | 2.25 (57.0) | 2.75 (70.0) | 6.53 (165.9) | 1.27 (32.3) | 2.19 (55.6) | 3.40 (86.4) | 1.05 (26.7) | 7.9 (3.6) | 9.5 (4.3) |
| 1 1/2" | 1.25 (31.8) | 6.50 (165.0) | 7.50 (109.5) | 2.45 (62.2) | 2.95 (74.9) | 8.10 (205.7) | 1.73 (43.9) | 2.88 (73.1) | 4.58 (116.3) | 1.63 (41.4) | 13.0 (5.9) | 16.1 (7.3) |
| 2" | 1.50 (38.1) | 7.00 (178.0) | 8.50 (215.9) | 2.67 (67.8) | 3.17 (80.5) | 8.10 (205.7) | 1.92 (48.8) | 3.06 (77.8) | 4.77 (121.2) | 2.01 (51.1) | 18.1 (8.2) | 22.1 (10.0) |
| 3" | 2.50 (63.5) | 8.00 (203.2) | 11.12 (282.6) | 3.62 (92.0) | — | 22.0 (558.8) | 3.88 (98.6) | 5.69 (144.5) | 7.22 (183.4) | 3.06 (77.7) | 39.5 (17.9) | 50 (22.7) |
| 4" | 3.25 (82.6) | 9.00 (228.6) | 12.00 (304.8) | 4.00 (101.6) | — | 22.0 (558.8) | 4.48 (113.8) | 6.31 (160.3) | 7.84 (199.1) | 4.03 (102.4) | 62 (28.1) | 80 (36.3) |
| 6" | 4.38 (111.3) | 10.50 (266.7) | 15.88 (403.3) | 4.25 (108.0) | — | 26.0 (660.4) | 6.19 (157.2) | 8.96 (227.6) | 11.21 (284.7) | 6.06 (153.9) | 125 (56.7) | 150 (68.0) |
| 8" | 5.69 (144.5) | 11.50 (292.0) | 16.50 (419.1) | 5.69 (144.5) | — | 26.0 (660.4) | 7.28 (184.9) | 10.05 (255.3) | 12.31 (312.7) | 8.00 (203.2) | 184 (83.5) | 225 (102.1) |
| 10" | 7.38 (187.5) | 13.00 (330.2) | 18.00 (457.0) | 7.12 (180.9) | — | — | 9.28 (235.7) | 12.76 (324.1) | — | 10.00 (254.0) | 310 (139.5) | 490 (220.5) |

| Valve Size | F | G | H | J | K | L |
|------------|------------------|-------------|-----------------|-----------------|-----------------|--------|
| 1/2" | .217 (5.51) | 3/8 UNF | .28 (7.11) | — | 1.89 (48.01) | 1/4-20 |
| 3/4" | .217 (5.51) | 3/8 UNF | .28 (7.11) | — | 2.13 (54.10) | 1/4-20 |
| 1" | .296 (7.52) | 7/16 UNF | .43 (10.92) | — | 2.50 (63.50) | 1/4-20 |
| 1 1/2" | .343 (8.71) | 9/16 UNF | .61 (15.49) | — | 1.39 (35.31) | 1/4-20 |
| 2" | .343 (8.71) | 9/16 UNF | .61 (15.49) | — | 1.39 (35.31) | 1/4-20 |
| 3" | .745 (18.92) | — | .653 (16.6) | 1.75 (44.45) | 3.38 (85.85) | M10 |
| 4" | .745 (18.92) | — | .653 (16.6) | 1.75 (44.45) | 3.38 (85.85) | M10 |
| 6" | 1.120 (28.45) | — | 1.031 (26.2) | 3.00 (76.2) | 4.00 (101.6) | M12 |
| 8" | 1.120 (28.45) | — | 1.031 (26.2) | 3.00 (76.2) | 4.00 (101.6) | M12 |
| 10" | 1.375 (34.93) | — | 1.252 (31.8) | 2.25 (57.15) | 8.25 (209.5) | 5/8-11 |

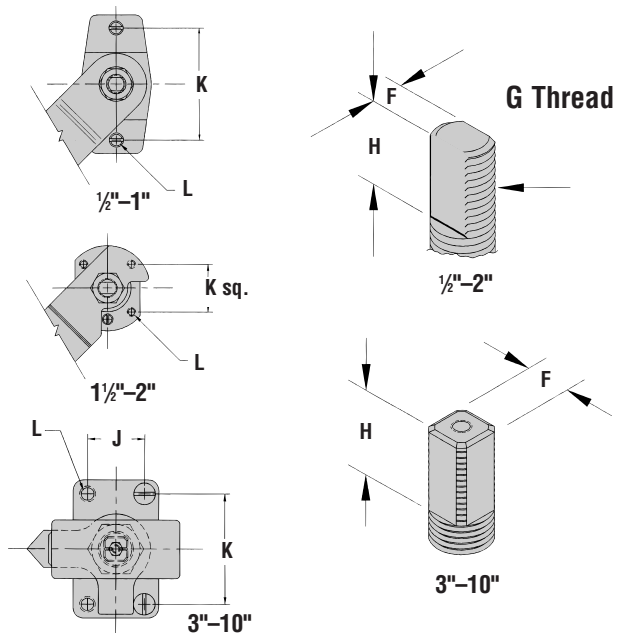

Dimensions – inches

Class 150 and 300 Flanged Valves ASME B16.5-1966

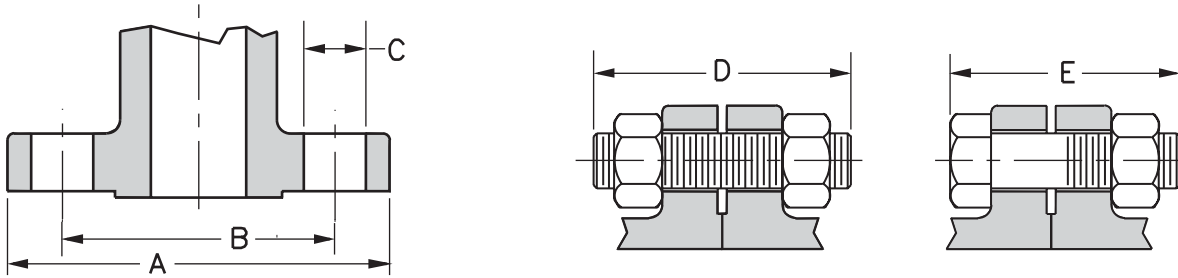

Class 150 Flanges

| Nominal Pipe Size | Outside Diameter of Flange A | Diameter of Bolt Circle B | Diameter of Bolt Holes C | Number of Bolts | Diameter of Bolts | Length of Stud Bolts with 2 Nuts D | Length of Bolts E |
|-------------------|---------------------------------|------------------------------|-----------------------------|-----------------|-------------------|---------------------------------------|----------------------|
| ½" | 3.50 | 2.38 | 0.62 | 4 | ½" | 2.25 | 2.00 |
| ¾" | 3.88 | 2.75 | 0.62 | 4 | ½" | 2.25 | 2.00 |
| 1" | 4.25 | 3.12 | 0.62 | 4 | ½" | 2.50 | 2.25 |
| 1½" | 5.00 | 3.88 | 0.62 | 4 | ½" | 2.75 | 2.50 |
| 2" | 6.00 | 4.75 | 0.75 | 4 | ⅝" | 3.25 | 2.75 |
| 3" | 7.50 | 6.00 | 0.75 | 4 | ⅝" | 3.50 | 3.00 |
| 4" | 9.00 | 7.50 | 0.75 | 8 | ⅝" | 3.50 | 3.00 |
| 6" | 11.00 | 9.50 | 0.88 | 8 | ¾" | 4.00 | 3.25 |
| 8" | 13.50 | 11.75 | 0.88 | 8 | ¾" | 4.25 | 3.50 |
| 10" | 16.00 | 14.25 | 1.00 | 12 | ⅞" | 4.50 | 4.00 |

Class 300 Flanges

| Nominal Pipe Size | Outside Diameter of Flange A | Diameter of Bolt Circle B | Diameter of Bolt Holes C | Number of Bolts | Diameter of Bolts | Length of Stud Bolts with Nuts D | Length of Bolts E |
|-------------------|---------------------------------|------------------------------|-----------------------------|-----------------|-------------------|-------------------------------------|----------------------|
| ½" | 3.75 | 2.62 | 0.62 | 4 | ½" | 2.50 | 2.25 |
| ¾" | 4.62 | 3.25 | 0.75 | 4 | ⅝" | 3.00 | 2.50 |
| 1" | 4.88 | 3.50 | 0.75 | 4 | ⅝" | 3.00 | 2.50 |
| 1½" | 6.12 | 4.50 | 0.88 | 4 | ¾" | 3.50 | 3.00 |
| 2" | 6.50 | 5.00 | 0.75 | 8 | ⅝" | 3.50 | 3.00 |
| 3" | 8.25 | 6.62 | 0.88 | 8 | ¾" | 4.25 | 3.50 |
| 4" | 10.00 | 7.88 | 0.88 | 8 | ¾" | 4.50 | 3.75 |
| 6" | 12.50 | 10.62 | 0.88 | 12 | ¾" | 4.75 | 4.25 |
| 8" | 15.00 | 13.00 | 1.00 | 12 | ⅞" | 5.50 | 4.75 |
| 10" | 17.50 | 15.25 | 1.12 | 16 | 1" | 6.25 | 5.50 |

Flowserve flanged valves are designed to conform to ASME B16.5-1996 standards. Selected dimensions from that publication are shown here for basic planning purposes only. For detailed flange dimensions, always refer to ASME B16.5-1996, available from the American Society of Mechanical Engineers, 345 East 47th Street, New York, NY 10017.

Parts Identification and Materials of Construction

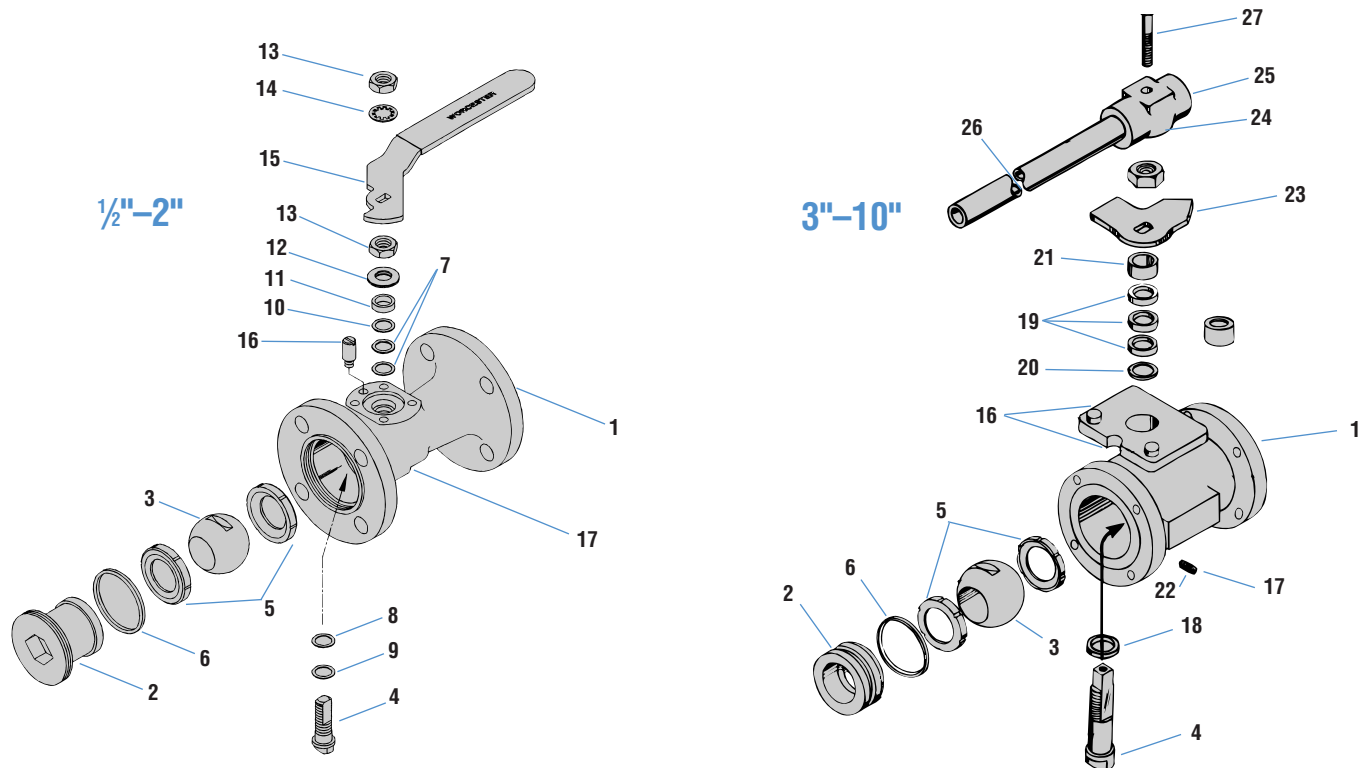

| Part No. | Part Name | Quantity | Materials |
|----------|--------------------------|---|--|
| 1 | Body | 1 | Carbon Steel ASTM A216-WCB, Black Oxide Coated; S.S. ASTM A351-CF8M; Ductile Iron (3"-8" 51 Series Only) |
| 2 | End Plug | 1 | Carbon Steel, Black Oxide Coated; Stainless Steel, Ductile Iron (3"-8" 51 Series Only) |
| 3 | Ball | 1 | 316 S.S.; Monel, Hastelloy C, Alloy 20 |
| 4 | Stem | 1 | Stainless Steel ASTM A479-316 COND. A., Monel, Hastelloy C, Alloy 20 |
| 5 | Seat | 2 | TFE, Reinforced TFE, Polyfill, UHMWPE |
| 6 | Body Seal | 1 | TFE, Buna, Viton, EPR, UHMWPE, 316 "S" Gasket; Graphite |
| 7 | Stem Seals (1/2"-2") | 2 | Polyfill or UHMWPE |
| 8 | Thrust Bearing | 1 | Polyfill |
| 9 | Thrust Bearing Protector | 1 | PEEK |
| 10 | Seal Protector | 1 | PEEK |
| 11 | Follower | 1 | Stainless Steel AISI 316L |
| 12 | Belleville Washers | 2 (manual) 4 (automated) | Carbon Steel, Zinc-Plated on Carbon Steel Valves; 301 Stainless Steel on Stainless Steel Valves |
| 13 | Retaining Nuts | 2 | Carbon Steel, Zinc-Plated on Carbon Steel Valves; AISI-300 Stainless Steel, Zinc-Plated on Stainless Steel Valves |
| 14 | Lockwasher | 1 | Carbon Steel, Zinc-Plated on Carbon Steel Valves; AISI-300 Stainless Steel on Stainless Steel Valves |
| 15 | Handle | 1 | Carbon Steel, Zinc-Plated, Vinyl Coated, on Carbon Steel Valves; ASTM A167-300 Stainless Steel, Vinyl Coated on Stainless Steel Valves |
| 16 | Stop Screw | 2 (1/2"-1") 1 (1 1/2"-2") 2 (3"-8") | Carbon Steel, Zinc-Plated on Carbon Steel Valves; AISI 300 Stainless Steel, Zinc-Plated on Stainless Steel Valve |
| 17 | Nameplate | 1 | AISI 304 Stainless Steel |
| 18 | Thrustbearing | 1 | TFE - 25% Glass Filled |
| 19 | Stem Seals (3"-10") | 3 | TFE - 15% Glass Filled |
| 20 | Centering Washer | 1 | AISI 316 Stainless Steel |
| 21 | Follower | 1 | ASME A276-316 COND. A Stainless Steel |
| 22 | End Plug Retention Screw | 4-12 | Stainless Steel, Zinc-Plated on Carbon Steel Valves; AISI 304 Stainless Steel on Stainless Steel Valves |
| 23 | Stop Plate | 1 | ASME A366 Carbon Steel, Zinc-Plated |
| 24 | Retaining Nut | 1 | Carbon Steel, Zinc-Plated on Carbon Steel Valves; AISI 303 Stainless Steel, Zinc-Plated on Stainless Steel Valves |
| 25 | Wrench Block | 1 | Carbon Steel |
| 26 | Wrench Extension | 1 | Carbon Steel |
| 27 | Hex Head Bolt | 1 | Carbon Steel, Black Oxide Coated |

Pneumatic and Electric Actuators for Series 51/52 Valves



Series 34
Pneumatic Actuator,
see brochure WCABR1004



Series 39
Pneumatic Actuator,
see brochure WCABR1003



Series 75
Electric Actuator,
see brochure WCABR1014



Series 72
Electri-SAFE Actuator,
see brochure WCABR1022

How To Order

| Size | Options (Blank if None) | Style | Body & End Plugs | Ball Stem | Seats** | Seals** | End Connection | V#’s |
|--|---|--------|--|--|--|--|--|---|
| 3" 1/2" 3" 3/4" 4" 1" 6" 1 1/2" 8" 2" 10" | V - Vacuum Service L - U.L. Approved (must Specify Service) X - Oxygen Service E - No handle, valve built for automation A - No handle† B - No handle† | 51, 52 | 2 - Ductile Iron* 4 - Carbon Steel 6 - 316 S.S. | 6 - 316 S.S. 7 - Monel A - Alloy 20 C - Hastelloy C | T - TFE R - Reinforced TFE P - Polyfill U - UHMWPE | T - TFE B - Buna V - Viton E - EPR Z - Graphite M - 316 "S" Gasket U - UHMWPE | 150 - ANSI 150# Flanges 300 - ANSI 300# Flanges | Blank - No Variations S7 - Complete S.S. Externals (manually operated valves only) V - Numbers See page 4 for listing |

**For metal seats, refer to brochure WCABR1030.

**Use only one letter if body seal is same material as seat. TM, RM, PM, TZ, RZ, PZ qualified to API 607. Refer to brochure WCABR1029.

*Ductile Iron valves available in Style 51, sizes 3"–8" only.

†To order a 1/2"–2" Series 51 or 52 valve for use with: 34 or 36 actuators, use prefix ordering code "A". (EXAMPLE: 1" A 5146 6 PM150)
39 or 75 actuators, use prefix ordering code "B".

Ordering Example: A 3" Series 51 with Ductile Iron body and end plug, Stainless Steel ball and Stainless Steel stem, Reinforced TFE seats, TFE seals and 150# flanges.

NOTE: Please refer to Specification sections for material availability. Standard Flowserve valves are assembled with silicon-based break-in lubricant.
For other options, consult your distributor or Flowserve.

Caution: Ball valves can retain pressurized media in the body cavity when closed. Use care when disassembling. Always open valve to relieve pressure prior to disassembly. Due to continuous development of our product range, we reserve the right to alter the product specifications contained in this brochure, as required.

Worcester® is a registered trademark of Worcester Controls. • Polyfill® is a registered trademark of Worcester Controls. • Pulsair® is a registered trademark of Worcester Controls.
Electri-SAFE® is a trademark of Worcester Controls. • Energy/Thermal Mizer™ is a trademark of Worcester Controls. • Viton® is a registered trademark of The DuPont Co.
Alloy 20® is a registered trademark of CRS Holdings, Inc. • Hastelloy® is a registered trademark of Haynes International. • Monel® is a registered trademark of Inco Alloys International.

Flowserve Corporation has established industry leadership in the design and manufacture of its products. When properly selected, this Flowserve product is designed to perform its intended function safely during its useful life. However, the purchaser or user of Flowserve products should be aware that Flowserve products might be used in numerous applications under a wide variety of industrial service conditions. Although Flowserve can (and often does) provide general guidelines, it cannot provide specific data and warnings for all possible applications. The purchaser/user must therefore assume the ultimate responsibility for the proper sizing and selection, installation, operation, and maintenance of Flowserve products. The purchaser/user should read and understand the Installation Operation Maintenance (IOM) instructions included with the product, and train its employees and contractors in the safe use of Flowserve products in connection with the specific application.

While the information and specifications contained in this literature are believed to be accurate, they are supplied for informative purposes only and should not be considered certified or as a guarantee of satisfactory results by reliance thereon. Nothing contained herein is to be construed as a warranty or guarantee, express or implied, regarding any matter with respect to this product. Because Flowserve is continually improving and upgrading its product design, the specifications, dimensions and information contained herein are subject to change without notice. Should any question arise concerning these provisions, the purchaser/user should contact Flowserve Corporation at any one of its worldwide operations or offices.

For more information about Flowserve Corporation, visit www.flowserve.com or call USA 1 800 225 6989.

FLOWSERVE CORPORATION
FLOW CONTROL DIVISION
1978 Foreman Drive
Cookeville, Tennessee 38501 USA
Phone: 931 432 4021
Facsimile: 931 432 5518